

**BEST MOTOR**Tel. 059 - 858059  
fax. 059 - 850410MOTORE-TRAZIONE  $\phi 244$  CON FLANGIA ANTERIORE PER RIDUTT."KORDEL-KE 460"  
(REV. 1 DEL 31/10/1997)

POTENZA POWER 8000 W	TENSIONE VOLTAGE 80 V	CORRENTE CURRENT 115 A	RPM 2450	SERVIZIO SERVICE S2 = 60'	SERVIZIO SERVICE S3 = -- %	CLASSE ISOL. F	VENTILAZIONE INTERNA	ECCITAZIONE SERIE (4-MORS.)	PESO WEIGHT Kg 68
----------------------------	-----------------------------	------------------------------	-------------	---------------------------------	----------------------------------	----------------------	-------------------------	--------------------------------	-------------------------

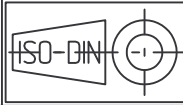
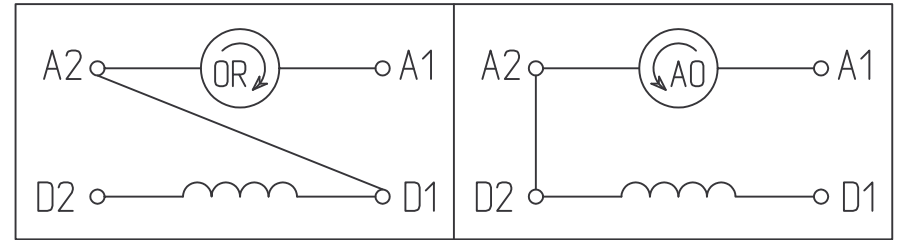
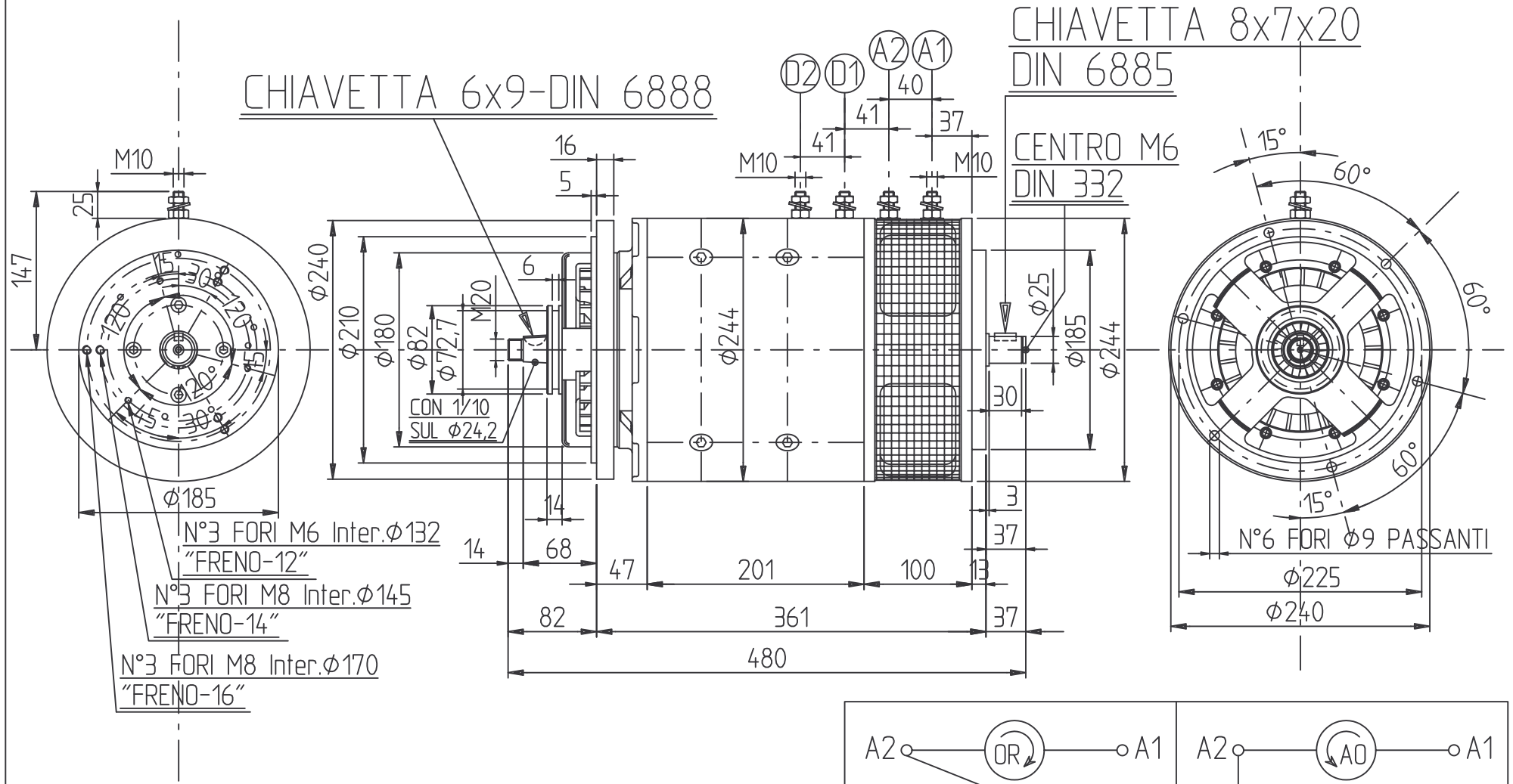

Cod. F1803100

Firma PROG. *S. Debbi***F1803100**