

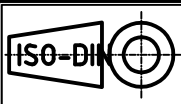

**BEST MOTOR**  
 Tel. 059 - 858059  
 fax. 059 - 850410



**MOTORE TRAZIONE  $\phi 177$**   
 (REV. 1 DEL 09/04/2008)

POTENZA POWER <b>12000 W</b>	TENSIONE VOLTAGE <b>24 V</b>	CORRENTE CURRENT <b>650 A</b>	RPM <b>2350</b>	SERVIZIO SERVICE S2 = <b>1'</b>	SERVIZIO SERVICE S3 = <b>2 %</b>	CLASSE ISOL. <b>H</b>	VENTILAZIONE <b>ESTERNA</b>	ECCITAZIONE <b>SERIE (4M)</b>	PESO WEIGHT <b>Kg --</b>
------------------------------------	------------------------------------	-------------------------------------	--------------------	---------------------------------------	--	-----------------------------	--------------------------------	----------------------------------	--------------------------------

LATO PORTASPAZZOLE

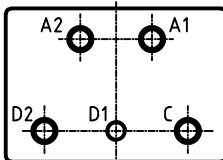

Nomenclatura morsettiera

N°2 Filetti M5 a 65°

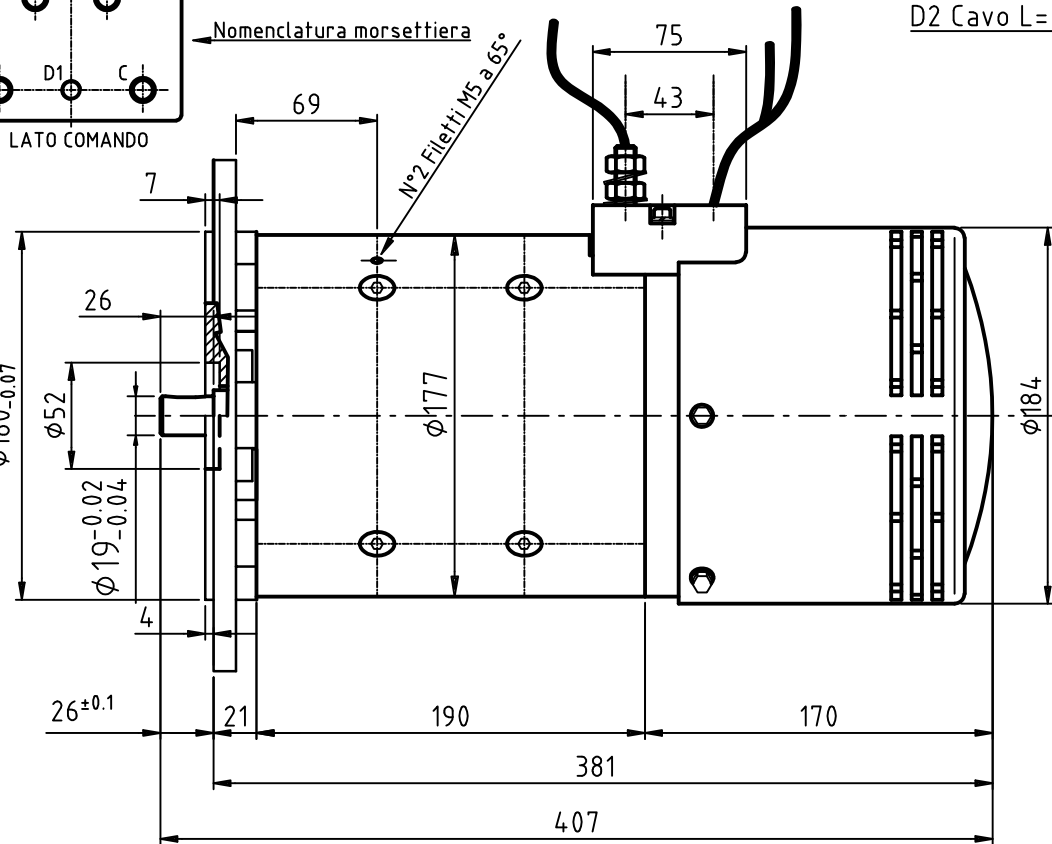

A2 Cavo L= 150mm

A1 Cavo L= 150mm

D2 Cavo L= 200mm

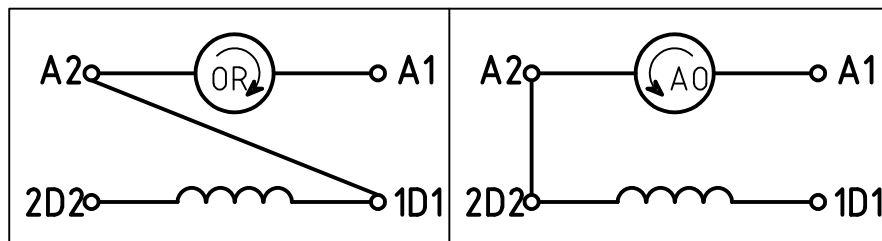
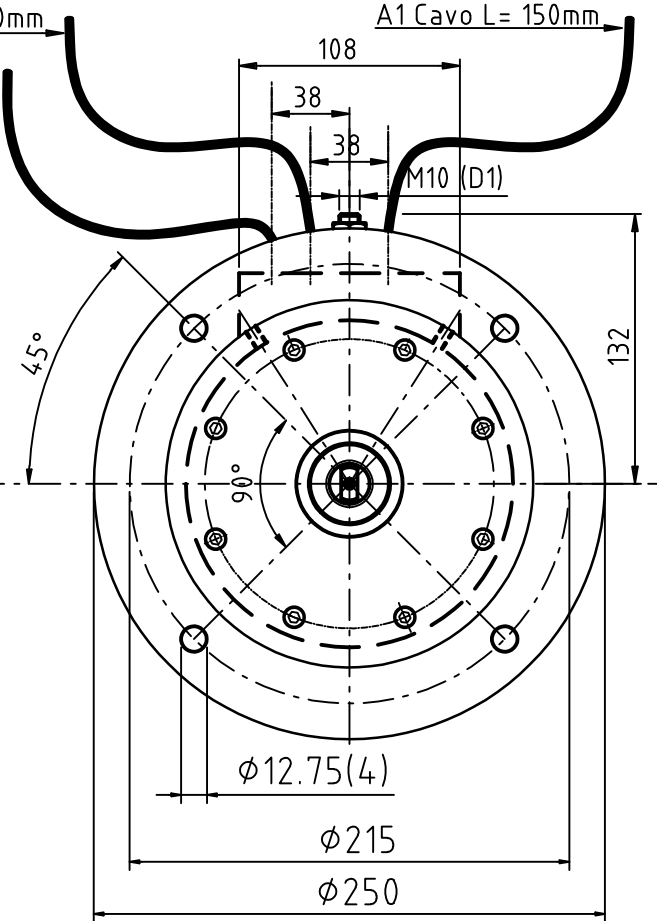

Cod. F1906200

Firma PROG. : PO M.

**F1906200**