

POTENZA POWER 4500 W	TENSIONE VOLTAGE 48VDC-32VAC	CORRENTE CURRENT 105 A	RPM 2850	SERVIZIO SERVICE S2 = 60'	SERVIZIO SERVICE S3 = 70 %	CLASSE ISOL. F	INDEX COOLING IC 410	ECCITAZIONE FREQ. (98 Hz)	PESO WEIGHT Kg 50 c.a
----------------------------	------------------------------------	------------------------------	-------------	---------------------------------	----------------------------------	----------------------	-------------------------	------------------------------	-----------------------------

SUPERSEAL-4vie (Encoder)  
SUPERSEAL 2VIE (KTY 84/130)  
SUPERSEAL 3VIE (FRENO)

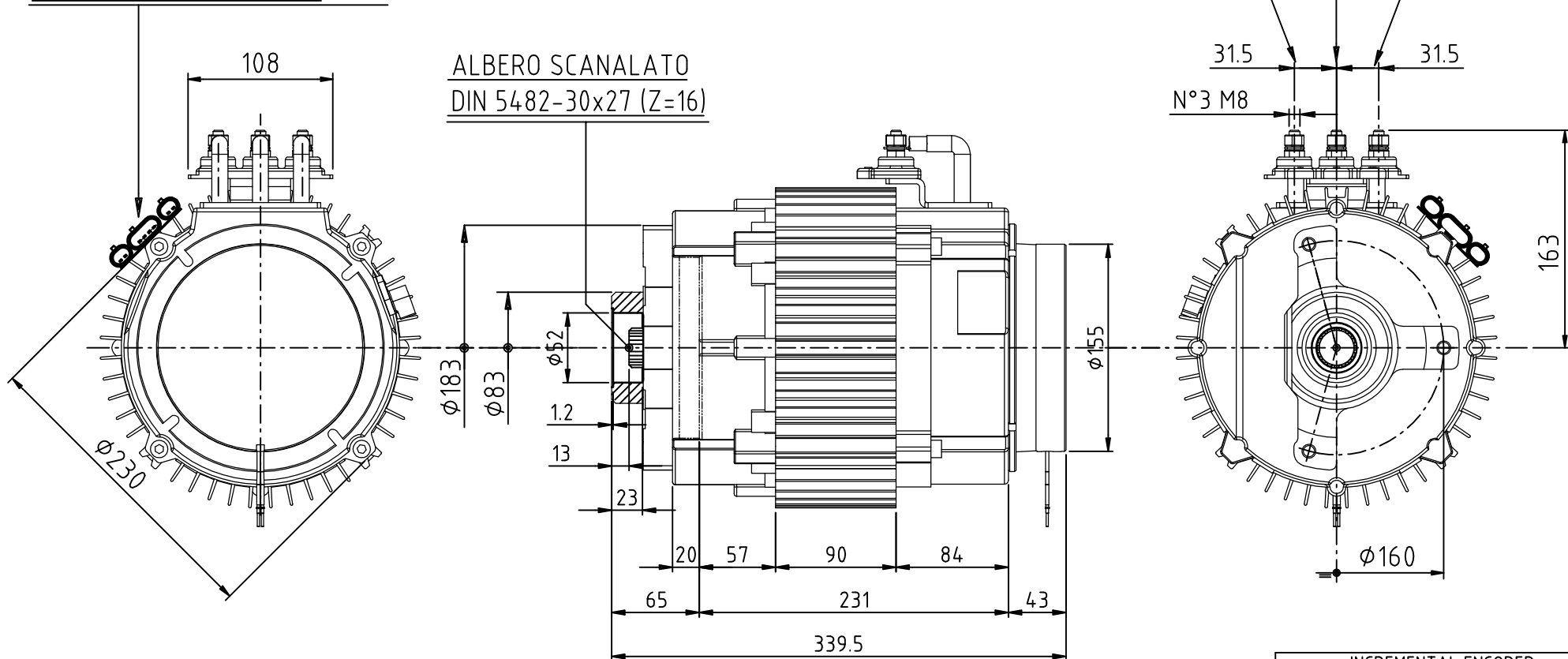

ALBERO SCANALATO  
DIN 5482-30x27 (Z=16)

INCREMENTAL ENCODER		
OUTPUT FORM:	OPEN COLLECTOR	
POWER SUPPLY:	+5 / +24 VDC	
OUTPUT CURRENT	20 mA max.	
N° PULSE REVOLUTION:	64	
N°PIN:	DESCRIPTION:	COLOUR:
1	+VCC	RED
2	SIGNAL B	BLUE
3	SIGNAL A	WHITE(Green)
4	GND	BLACK

Cod. G141183P

Firma PROG. : Po M.

SUPERSEAL FRENO	
N°PIN:	DESCRIPTION:
1	CAVO FRENO
2	--
3	CAVO FRENO

