

POTENZA POWER 9,5 KW	TENSIONE VOLTAGE 90 V	CORRENTE CURRENT 135 A	RPM 1500	SERVIZIO SERVICE S2 = 60'	SERVIZIO SERVICE S3 = 70 %	CLASSE ISOL. F	VENTILAZIONE ESTERNA	ECCITAZIONE AC (53Hz)	PESO WEIGHT Kg --
-----------------------------------	------------------------------------	-------------------------------------	--------------------	--	---	-----------------------------	--------------------------------	---------------------------------	--------------------------------

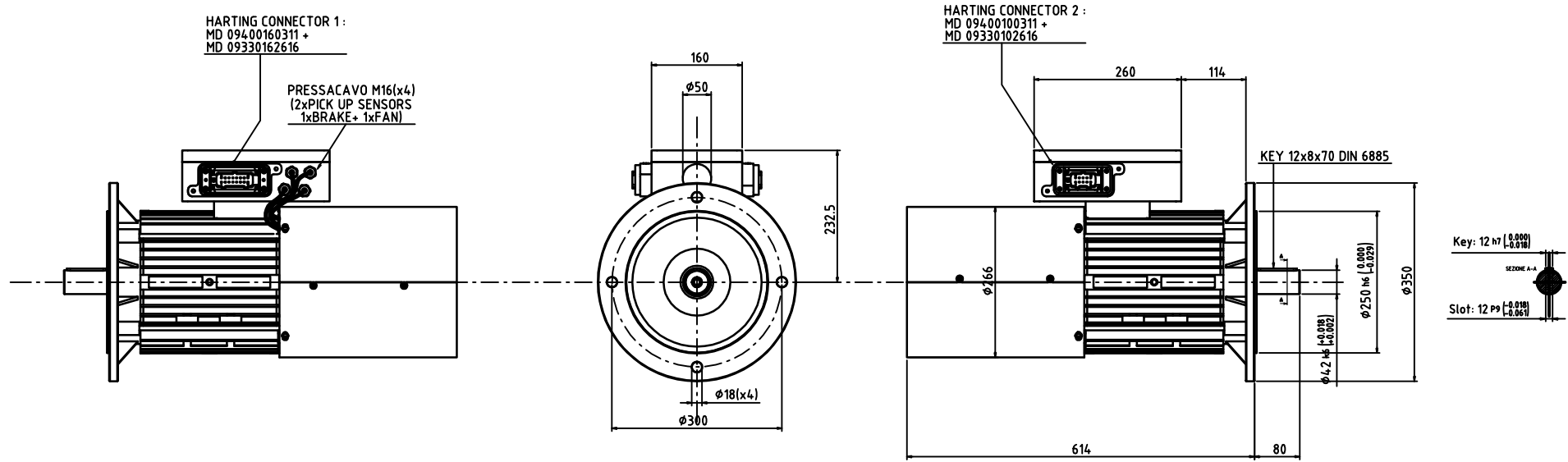

HARTING CONNECTOR 1 :

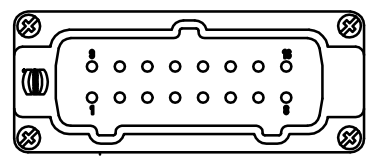

- | | |
|-----------------|-----------------|
| 1: +VCC (1) | 9: Signal B (2) |
| 2: GND(1) | 10: PT 100 |
| 3: Signal A (1) | 11: FREE |
| 4: Signal B (1) | 12: FREE |
| 5: PT 100 | 13: FREE |
| 6: +VCC (2) | 14: FREE |
| 7: GND (2) | 15: FREE |
| 8: Signal A (2) | 16: FREE |

HARTING CONNECTOR 2 :

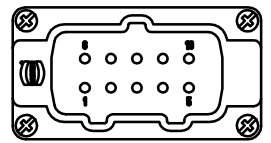

- | | |
|----------------|-------------|
| 1: Fan L1 | 6: PT 100 |
| 2: Fan N | 7: KTY (1) |
| 3: Brake +24 V | 8: KTY (1) |
| 4: Brake 0 V | 9: KTY (2) |
| 5: PT 100 | 10: KTY (2) |

COLORE RAL 9005 Bucciato+C5M

Cod.: G1901200

Firma PROG. : Po M.